

PIAB LKV Overload Guard



The PIAB LKV Crane Overload Guard is designed for easy installation without disturbing the crane, particularly on overhead traveling cranes, container handling equipment and haulages where operators may not know when they have an overload condition.

Range of Application

The PIAB LKVE is intended for use as an overload guard or a slack rope switch in lifting equipment and is

made in a range for forces up to 16000 kp in a single rope part and for max. 44 mm line diameter.

Function

The PIAB LKV is attached to a stationary rope part. The rope is deflected by a small angle between the two wheels and the clamping jaw. When loaded, the rope tends to straighten. This applies a force to the clamping jaw and to the pull rod. When the set switch value is reached, the pull rod operates a micro switch and a close/open circuit is made. The spring element of the load cell is preloaded, reducing pull rod movement to the last 25% of full load.

For the best possible accuracy the LKV is equipped with case-hardened wheels with carefully designed rope grooves. To ensure correct fitting on the rope diameter, the wheels and the clamping jaws are provided with rope tracks at intervals of 4 mm. The wheels should not be regarded as wheels but rather as moving support points, as the peripheral movement on the wheels at full line load is only about 0.6 mm, including the extension of the rope.

Protection against corrosion

The PIAB LKV is fully pressure tight. Each instrument is tested under pressure. The PIAB LKV fully conforms to the international protection specification class IP 67 acc. to IEC 529. Externally it is Zinc coated and yellow

chromated. The wheel bearings are sealed with O-rings and lubricated with MoS₂.

If the LKV is to be used in a very corrosive environment, it may be polyester-lacquered.

Safety

The overload guard is not directly included in the rope system and does not affect the construction of the lifting equipment.

The locking device prevents unauthorized interference with the switch setting. In spite of the changes that normally take place on the rope diameter, the PIAB LKV maintains its set switch value even after fitting to a new rope.

As the LKV is fully pressure tight, it is well protected against dust, dirt, damp, frost and other atmospheric conditions.

The power-absorbing element consists of specially made Belleville washers dimensioned to resist fatigue. The spring washers cannot be overloaded.

The PIAB LKV can be overloaded by 100% without affecting the repeatability.

Installation

Install the PIAB LKV directly to the static rope part close to the anchor point or close to a compensating pulley. The rope needs not be unloaded. Set the switch value with the spanner provided for this purpose. The PIAB LKV is usually delivered with the switch value set. Check the switch

value with a buzzer or similar device. Connect the PIAB LKV electrically, e.g. to the control circuit of the hoisting movement or the top limit switch. Test-load for control and possible readjustment. Seal the set value with the locking clamp and the padlock provided.



Contact function

The microswitch has alternative contact functions. When the PIAB LKV is used as an overload guard, the normally closed function should always be used. The microswitch has self-cleaning, gold-plated silver contacts, also suitable for operation on low current/voltage (under 10V and/or 60mA). The difference between

contact at rising and falling load is 5-8%. This hysteresis is somewhat reduced at lower loads and increases slightly at higher load values. To avoid "chatter" of the contacts and contactors if the load should start to sway, a time relay can be connected to prolong the reconnection of the hoisting movement.

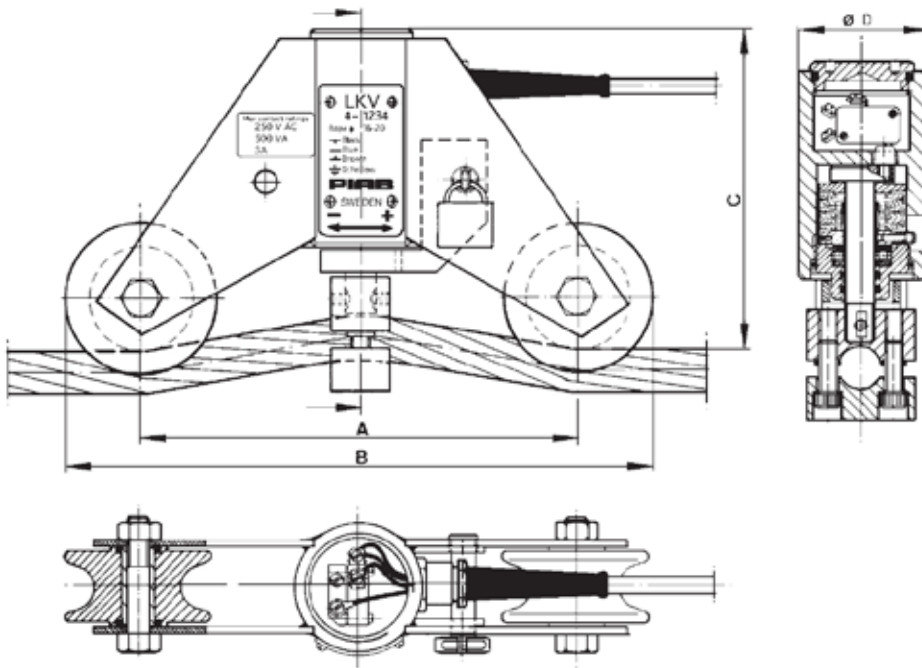

The drawing is for a PIAB LKV. The different dimensions differ slightly in design.

TYPE	MAX. SWITCH VALUE IN KG	FOR ROPE DIMENSION Ø IM MM	DEAD WEIGHT IN KG	MEASUREMENTS IN MM			
				A	B	C	D
LKV-1	1000	5-8 8-12 12-16 16-20	5	200	268	142	60
LKV-2	2000						
LKV-4	4000						
LKV-8	8000	16-20 20-24 24-28 28-32 32-36	12	300	403	208	86
LKV-12	12000						
LKV-16	16000						
		32-36 36-40 40-44	22	480	600	215	135

PIAB LKV used as a slack line switch.

TYPE	SWITCH VALUE INTERVAL IN KG	FOR ROPE DIMENSION Ø IM MM	DEAD WEIGHT IN KG	MEASUREMENTS IN MM			
				A	B	C	D
LKV 01	40 - 100		as LKV-1 above				
LKV 08	200 - 800		as LKV-8 above				

Technical Data

MEASUREMENTS

See drawing and table.

REPEATABILITY

±1.5 % of the max.capacity.

MAX CONTACT LOAD

250 VAC, 500 VA, 3A.

THE MECHANICAL LIFE LENGTH OF THE MICROSWITCH

20 mill.cycles.

WORKING TEMPERATURES

Continuous operation up to +60°C.

Specially designed PIAB LKV:s can be supplied for up to +200°C. The cable is a 4m weather and oil resistant cable RDO 4x1.5 mm²

WIRING DIAGRAM

Also inscribed on the badgeplate.

-  Black
-  Blue
-  Brown
-  Green/Yellow

Applications for the **PIAB** LKV

To determine the dimension of the PIAB LKV and set the right switch value, we need to know:

- Max. capacity of the crane
- Number of rope parts
- Rope diameter

The switch value is normally set at factory, but can be made on location. Instructions and tools are included in the delivery.



On tower cranes of different types, the PIAB LKV is installed on the backstay and functions as a moment switch. PIAB LKV is sealed according to IP67 and functions very well outdoors, with constant reliability even in rough climate.



A typical installation of the PIAB LKV, installed at the anchor point of the hoist rope in a traveling crane. The PIAB LKV functions either as an overload guard or as a slack line switch.



9010-1_131023

 **GIGAsense**

GIGAsense AB • Stationsvägen 16
SE - 18450 Åkersberga • SWEDEN
Phone: +46 (0)8 540 839 00
e-mail: info@gigasense.se • webb: www.gigasense.se

